



## MySpot 500 Remote Controlled Parking Barrier v1

**MySpot™ 500** is an advanced self-contained remote controlled parking barrier. It is designed to control access to individual parking spaces. This field is known as ASSP (Automatic Single Space Parking) barriers).

**Rugged:** The barrier is constructed from 50 mm (2") powder-coated steel tube. When vertical, the barrier is 565 mm tall (22"), making it the tallest wireless parking barrier in the industry. In its lowered position, it is only 77 mm high (3"), allowing unobstructed passage to even low road-clearance cars. Height is critical to insure visibility of the barrier, especially when backing up with today's high back, wedge-shaped cars.

**Super Efficient:** Advanced mechanical and electronic design make this product a power-sipper. The high efficiency direct-drive motor raises and lowers the barrier in 6 seconds. The advanced electronics control the voltage and current consumption to obtain a 2-3 year battery life from 5 off-the-shelf alkaline "D" batteries. Our closest competitor's unit requires recharging its battery every 3 months—and it is only 80% the height and 70% the width of the

### FEATURES

- **Highly visible, tall steel barrier**
- **Professional grade, robust Construction**
- **Self Contained, sealed**
- **2 year battery life - standard D cells**
- **No external power required**
- **no digging**
- **Radio Controlled**
- **Abuse resistant, water sealed**
- **Built-in guidance and diagnostics LEDs**
- **Quiet operation**

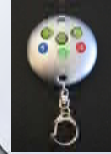

**MySpot 500 Remote-Controlled Barrier**

MySpot 500.

**Survivor:** Minor collisions and bumping of cars into barriers (and walls, and other cars) are inevitable over time. If excessive force (over 50 lb.) is applied to the barrier, the barrier will yield until the external force is removed. This protects the barrier and the roadway from damage, saves on service calls and assures that the barrier will continue to protect the space after the collision. If a car forces its way, its undercarriage is likely to be damaged as the car *pulls out*.

The MySpot500 is housed in a water-tight aluminum extrusion. It meets IP67 standards for water and dust resistance.

**Installation:** The pre-assembled barrier is placed at the center of the parking bay and is attached to the surface using 4 masonry anchors provided in the kit. Installation on *asphalt* requires the use of our optional AK-4 asphalt anchor kit. No wires need to be



10 Ridge Rd  
West Orange, NJ 07052  
USA

Tel: 1.973.669.8214  
Fax: 1.973.669.5161  
Email: [info@designatedParking.com](mailto:info@designatedParking.com)  
WEB: [www.designatedParking.com](http://www.designatedParking.com)



## MySpot 500 Remote Controlled Barrier

brought to the unit — not for power, not for recharging, and not for remote control.

**Radio Control:** The *MySpot 500* is supplied with two radio transmitters, with a control range of 20 meters (60 feet). Each barrier can be paired with a total of 15 transmitters. The radio code system is compatible with the HomeLink® programmable visor transmitter, available as a factory option on luxury cars worldwide.

**Integration:** MySpot 500 can be integrated with facility-wide parking systems. Contact us for details.

### Competitive Comparison:

- **Size:** The MySpot 500 is physically larger than most Automatic Single-Space Parking Barriers on the market.
- **Attractive:** The MySpot 500 is an elegant and appealing product that enhances the look of your property.
- **Battery:** All competitive ASSP barriers use a rechargeable lead-acid battery. These batteries have a life expectancy of 2 years at best, and can handle a limited number of recharges. The batteries self discharge quickly, and, combined with the power consumption from their bar-



rier, need recharging every 3 months.

Recharging is a great inconvenience. The barrier must be opened up, battery removed, taken indoors for charging, then 12 hours later placed back in the housing.

The MySpot 500 uses alkaline batteries that have a 10 year shelf life. Advanced mechanical and product design reduces power consumption to the point where batteries need to be replaced only every 2-3 years in residential applications (4 activations per day). No recharging is required.

- **Advanced Control Options:** The handheld fobs that are supplied with the barrier can each control 9 individual barriers side by side. None of our competitors can control more than 3 or 4 barriers. Each barrier can be controlled by 15 transmitters. None of our competitors can be controlled by more than 3 remotes.
- **Central Controller:** Up to 250 barriers can be controlled wirelessly from one remote location, using our PK250 keypad controller.
- **Water Proof:** Only the MySpot 500 can operate and survive in locations where water pools after the rain. There are no exposed wires, batteries or antenna that can be damaged by water. None of our competitors can make this claim.

Continued on next page



10 Ridge Rd  
West Orange, NJ 07052  
USA

Tel: 1.973.669.8214  
Fax: 1.973.669.5161  
Email: info@dp-corp.com  
WEB: www.dp-corp.com



# MySpot 500 Remote Controlled Barrier

**How It Works:** When the unit receives a command from a paired transmitter, it will activate the motor to raise the barrier (if the barrier was down), or to lower the barrier, if it was up. An electronic sensor tracks the position of the barrier and, if it detects interference with the rise of the barrier (e.g. there is a car over the barrier as it rises), it will bring the barrier down automatically.

Once the barrier has reached the end of its travel, it will stop and lock the shaft to resist tampering with the barrier. Whatever external forces are applied to the barrier will be absorbed

by a special defense mechanism and will not be transmitted to the motor itself. The defense mechanism will return the barrier to its pre-tampering position on its own without use of battery power.

The antenna is hidden behind the "reserved" label. It is a state of the art design that provide excellent sensitivity to the transmission from the handheld fob transmitter. Two bright LED indicators are visible through the label, to provide guidance and diagnostics, including low-battery warning.

Battery replacement can be done without lifting the assembly from the ground.

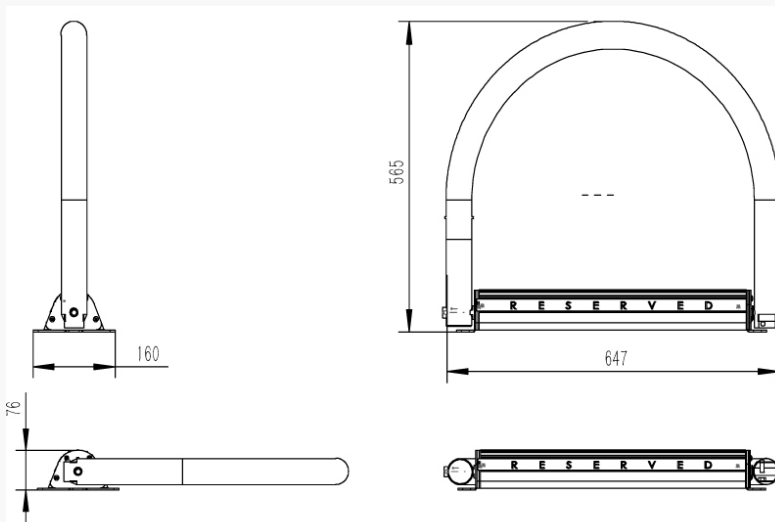

Packing Information	
Dimensions, cm	70x68x8
Volume	0.04 CBM
Weight	11 Kg (25 lbs)
Stacking	14
Country of origin	China
Harmony code	8479.79

Remote Control Specs	
Model: HTE	P/N: 01-6022
No. of codes	1,000,000
No. of barriers	9
Range	16m (50')
Battery	CR2032 (1)
Battery life	>5 years
Certification	CE, FCC

Barrier Unit Specifications	
Max No. of Remotes	15
Response time	<2 seconds
Max tire weight	1000 Kg/ 2200 lbs
Batteries	"D" (5)
Battery Life (years)	>2 Years
Battery Life (cycles)	10,000
Certification	CE, FCC
Temperature	-25C to 65C
Water rating	IP67

MySpot 500 Kit	
P/N 01-6240	
Barrier assembly	1
HTE transmitters	2
Masonry anchors	4
Hardware kit	1
Manual	1

©HomeLink is a trade mark of Johnson Controls

™MySpot is a trade mark of Designated Parking Corp.  
Covered by one or more US and international patents

Specifications and functionality subject to change without notice



10 Ridge Rd  
West Orange, NJ 07052  
USA

Tel: 1.973.669.8214  
Fax: 1.973.669.5161  
Email: info@dp-corp.com  
WEB: www.dp-corp.com