



MySpot 200A Wireless Remote Controlled Parking Barrier with Auto-Rise

MySpot™ 200A is a low cost, self-contained, remote controlled barrier. The "200A" is **self-powered** and restricts unauthorized access to parking spaces, driveways and access ramps, while providing the convenience of remote control to authorized vehicles.

MySpot 200A uses a proprietary method of capturing energy from the vehicle's weight and storing the power to lower and raise the barrier on command. This eliminates the need to connect the device to an electrical power source, or the bulk and cost of batteries with solar panel recharging.

Installation is simple and fast – no digging or major site preparation is required. Two steel plates are mounted on the *surface* of the parking space or driveway using bolts or a construction-grade adhesive. The MySpot 200 pods are then attached to these plates with security bolts.

The energy storage system and the electronics that manage it are sealed in a rugged housing ("PowerPod"), to resist water, debris and harsh environment. A second housing ("IdlePod"), without active components, is mounted on the other end of the barrier acting as a bearing.

The barrier is 43" (109 cm) long and stands 16.5" (42 cm) tall when raised. A "Reserved" reflective label is affixed to the front of the barrier.

If excessive force is applied to the barrier, a safety mechanism acts to disengage the barrier from the PowerPod. This prevents internal damage to the pod mechanism, to



MySpot 200 remote-controlled barrier and remotes. It automatically rises after the car pulls out.

the barrier itself and protects the bases from being pulled off the driveway. A disengaged barrier will automatically re-engage when the force is removed.

MySpot 200A is supplied with two radio transmitters. The system can accommodate up to 15 transmitters. The radio code system is compatible with the HomeLink® programmable visor transmitter, available as a factory option on luxury cars worldwide. The radio receiver in *MySpot 200* is powered by replaceable, common Alkaline "D" batteries, with over 2 years' life expectancy.

HIGHLIGHTS

- Self Contained, self powered
- No external power, no digging
- Anchored and/or glued to pavement
- 16.5" (42 cm) high barrier
- 4.3" (11 cm) silhouette when access is allowed
- Radio Controlled
- 2+ years operation on D batteries
- Low installed cost



MySpot 200A Remote Controlled Barrier

HOW IT WORKS

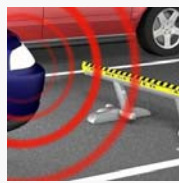

A A Signal from the remote in the approaching car releases the barrier



B The barrier falls from its own weight...



C ...and comes to rest about 10 cm (4") from the ground



D The car drives over the barrier and forces it to the ground, compressing a spring in the mechanism



E After the car leaves the space, an internal sensor ...



F ...releases the energy in the compressed spring and raises and locks the barrier in the Up position.

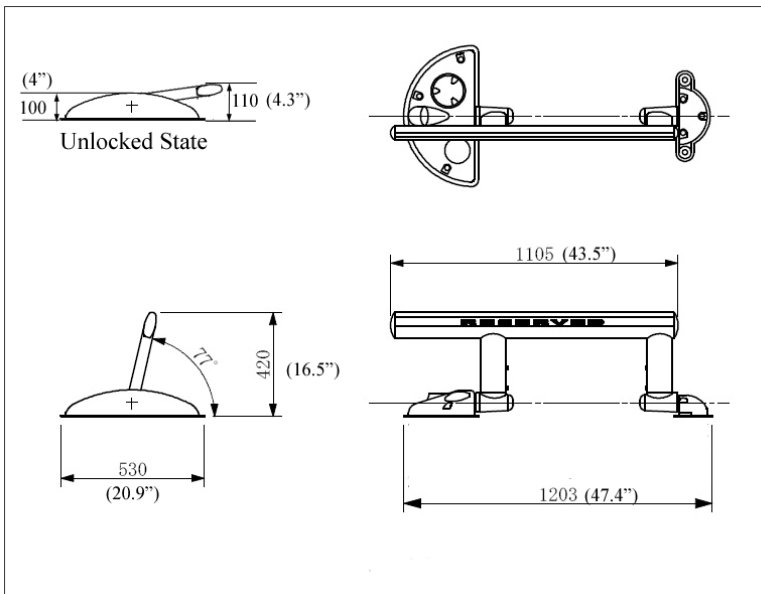

Packing Information	
Dimensions, cm	115x56x14
Dimensions, inch	46x23x5.3"
Volume	0.09 CBM
Weight	28 Kg (62 lbs)
Stacking	14
Country of origin	China
Harmony code	8479.89.9897

MySpot 200 Kit:	
PowerPod	1
IdlePod	1
Barrier	1
Remote controls	2
Drill template	1
Masonry anchors	7
Hardware kit	1
Security wrench	1
Manual	1
Mounting plates	2

Remote Control Specifications	
No. of codes	4,000,000
No. of barriers	9
Range	>8m (25 feet)
Batteries	CR2016 (2)
Battery life	>5 years
Certification	CE, FCC

Barrier Unit Specifications	
No. of Remotes	15
Response time	<2 seconds
Max tire weight	680 Kg/ 1500 lbs
Batteries	"D" (5)
Battery Life	2 Years
Certification	CE, FCC

©HomeLink is a trade mark of Johnson Controls
 MySpot is a trade mark of Designated Parking Corp.

Specifications and functionality subject to change without notice



10 Ridge Rd
 West Orange, NJ 07052
 USA

Tel: 1.973.669.8214
 Fax: 1.973.669.5161
 Email: info@dp-corp.com
 WEB: www.dp-corp.com